

Global Information Systems:

Localization and Internationalization (5)

Prof. Dr. Jan M. Pawlowski

11.10.2011



1934 2009

UNIVERSITY OF JYVÄSKYLÄ

Contents

- Introduction
- Definitions and Terms
- Design approaches
- Summary



1934 2009

UNIVERSITY OF JYVÄSKYLÄ

The Open Unified Process – Disciplines

- Architecture
 - Architecture Notebook
- Configuration and Change Management
- Development
 - Design
 - Build
 - Developer Test
 - Implementation
- Project Management
 - Iteration Plan
 - **Project Plan**
 - Work Items List
 - **Risk List**
- Requirements
 - Supporting Requirements Specification
 - Vision
 - Use Case
 - Glossary
 - Use-Case Model
- Test
 - Test Case
 - Test Log
 - Test Script
- Roles
- *Artefacts / Support*

[Source: <http://www.epfwiki.net/wikis/openup/>]



1934 2009

UNIVERSITY OF JYVÄSKYLÄ

Samples

تلا قرى زجلا

Startseite (M) Feeds (J) Drucken Seite

ملخص الخبر

أعلن البنتاغون الأمريكي حالة التعيين في صفوف جنوده للمساعدة في جهود إطفاء الحرائق الضخمة التي اندلعت في ولاية كاليفورنيا. وقد تسببت تلك الحرائق في مقتل خمسة أشخاص وإصابة 45 آخرين.

البنتاغون يعلن التعبئة وحرائق كاليفورنيا تجلي مئات الآلاف

الأخبار الفضائية المعرفة الأعمال English البث الحي

روابط أخرى

الأربعاء 1428/10/12 هـ - الموافق 2007/10/24 م (آخر تحديث) الساعة 18:44 (مكة المكرمة)، 15:44 (غرينتش)

فصائل من متحمدي دارفور تصل إلى ليبيا للمشاركة في مؤتمر سرت وآخر

إغلاق كربلاء أمام الزوار ومصرع وإصابة العشرات ببغداد
فرضت السلطات العراقية حظرا على دخول كربلاء لغير سكان المدينة، في إطار سعيها لتهنئة الأوضاع هناك بعد مقتل وإصابة عشرين شخصا بينهم 14 من الشرطة خلال الأيام الماضية. وفيما لا زال التوتر يسيطر على البصرة، قتل ثمانية بانفجارين ببغداد صباح اليوم.

إصابة إسرائيلي بالضفة وتوصية بقطع الكهرباء عن غزة
أصيب إسرائيلي بعد أن أطلق مسلحون في سيارة النار عليه بينما كان يقف في موقف للحافلات بمستوطنة أرييل بالضفة الغربية، من جهة أخرى أوصى مسؤولون إسرائيليون بالبدء بقطع التيار الكهربائي عن قطاع غزة تنفيذا لقرار يعتبره كيانا معاديا.

العراق يلغي حصانة الشركات الأجنبية
قررت الحكومة العراقية إلغاء حصانة الشركات الأجنبية العاملة في البلاد والتي أصدرتها سلطة الائتلاف المؤقتة عام 2004. يأتي هذا

أزمة دارفور

الكردي.. دروب التاريخ الوعرة

هذه الصفحة برعاية

رمضان كريم

Fertig Internet 100%

Samples

Al Jazeera English - Front Page

Startseite (M) Feeds (J) Drucken Seite



ALJAZEERA.NET

WATCH NOW
FRONT PAGE

- AFRICA
- AMERICAS
- ASIA-PACIFIC
- CENTRAL/S. ASIA
- EUROPE
- MIDDLE EAST

FOCUS
BUSINESS
SPORT
PROGRAMMES
WEATHER
YOUR VIEWS

SEARCH
ABOUT US
ARABIC
DOCUMENTARY

RSS
LOG IN

UPDATED ON:
WEDNESDAY, OCTOBER 24, 2007
19:04 MECCA TIME, 16:04 GMT

For every child
Health, Education, Equality, Protection
ADVANCE HUMANITY







Turkey 'hits PKK targets in Iraq'
Military sources say warplanes and troops attacked positions across the border.



Nato urged to up Afghan commitment



Israel set to sever power to Gaza



Sri Lanka furore over LTTE corpses



Roadside bombs hit Baghdad suburb

Now:
News
Next(in 10 min):
Witness

ALJAZEERA
TODAY'S SCHEDULE

ALJAZEERA
Job Vacancies

IN VIDEO

Delhi's menacing monkeys 

Turtles under threat in Malaysia 

POLL

Who should act to stop Kurdish attacks in Turkey?



California fires force mass exodus
Nearly a million people abandon their homes as president declares an emergency.



Iraq clamps down on security firms
New law to revoke immunity of foreign security contractors from prosecution.

Fertig

Internet 100%

Samples

Navigation bar: Startseite (M) | Feeds (1) | Drucken | Seite



มหาวิทยาลัยเจ้าพระยา

CHAOPRAYA UNIVERSITY

HONOR ORDER SPIRIT UNITY

[English Version](#) | [Home](#) | [Contact Us](#) | [SiteMap](#)

มหาวิทยาลัยของคนภูมิภาค

เพื่อสร้างคนระดับสากล



:: Information ::
:: Service ::

รู้จัก มจพ. ::

การสมัครเข้าศึกษาต่อ ::

- ▶ ระดับปริญญาตรี
- ▶ ระดับปริญญาโท
- ▶ ระดับปริญญาเอก

ทุนการศึกษา ::

หอพักนักศึกษา ::

- ▶ หอพักนักศึกษาชาย
- ▶ หอพักนักศึกษาหญิง

แผนที่การเดินทาง ::

ประมวลภาพกิจกรรม ::

สถาบันการศึกษาในเครือฯ:

-  กลุ่มบริษัทในเครือฯ:

:: Faculty ::

บริหารธุรกิจ ::

CPU Announcements

ข่าวสารประชาสัมพันธ์



มหาวิทยาลัยเจ้าพระยา

รับสมัครนักศึกษา ปี' 2550

[รับสมัครระดับ](#) | [ปริญญาตรี](#) | [ปริญญาโท](#) | [ปริญญาเอก](#)

ประกาศ



(9 พ.ค. 2550)

รายชื่อผู้มีสิทธิ์เข้าศึกษาต่อในระดับบัณฑิตศึกษาฯ (เพิ่มเติม) (ดูรายละเอียด)

ขอแสดงความยินดีกับนักกีฬาชวโค

Samples

★ ☆ The University Centre in Svalbard, UNIS Startseite (M) Feeds (J) Drucken Seite



News
About UNIS
Studies
Research
Student-life 78°N
Library
Staff
Vacant Positions
International Polar Year

Online Environmental data
Links
Publication Series
IT Services
UNIS WebMail
Webcamera
Search UNIS WEB
Downloads / Forms
Observing Avalanches

The University Centre
in Svalbard
PB 168



Creative Adaption to Climate Change

22.10.07
Dr. James Lovelock, originator of the Gaia theory and First Holder of the Arne Næss Chair in Global Justice and the Environment, will give a special lunch seminar at UNIS on Wednesday October 24th.

Time and place: 12:00 in auditorium Møysalen

[Read more about Dr. Lovelock](#)

We are seeking experts in Arctic Energy and Environment

Application deadline: November 1 2007

Vacant positions at UNIS

Job position	Deadline
3 faculty positions in Arctic Energy & Environment	01.11.2007
Professor/Assoc. Professor in Marine Invertebrate Ecology	15.11.2007
Adjunct Professor/Adjunct Assoc. Professor in Microbiology	15.11.2007

Definitions

- ❏ Internationalization (I18N) is the process of generalizing a product so that it can handle multiple languages and cultural conventions without the need for redesign. Internationalization takes place at the level of program design and document development (W3C, 2007)
- ❏ Localization (L10N) is the process of taking a product and making it linguistically and culturally appropriate to a given target locale (country/region and language) where it will be used (W3C, 2007)

Definitions

- ❏ Globalization (G11N) defines a business strategy and business activities to act on a global market.
- ❏ A Locale is a geographic location and a language of a region (e.g., Germany, French-speaking Quebec, Central Finland) – classes based on a locale are locale-sensitive



1934 2009

UNIVERSITY OF JYVÄSKYLÄ

Types of internationalization

- Application development (business logic)
- User interface design (presentation logic)
- Time
 - Run-time
 - Compile-time
 - Design-time
- Aspects
 - Software
 - Documentation (process documentation, help, manual)
 - Web pages
 - Learning materials
 - Knowledge & experiences



1934 2009

UNIVERSITY OF JYVÄSKYLÄ

Types of internationalization

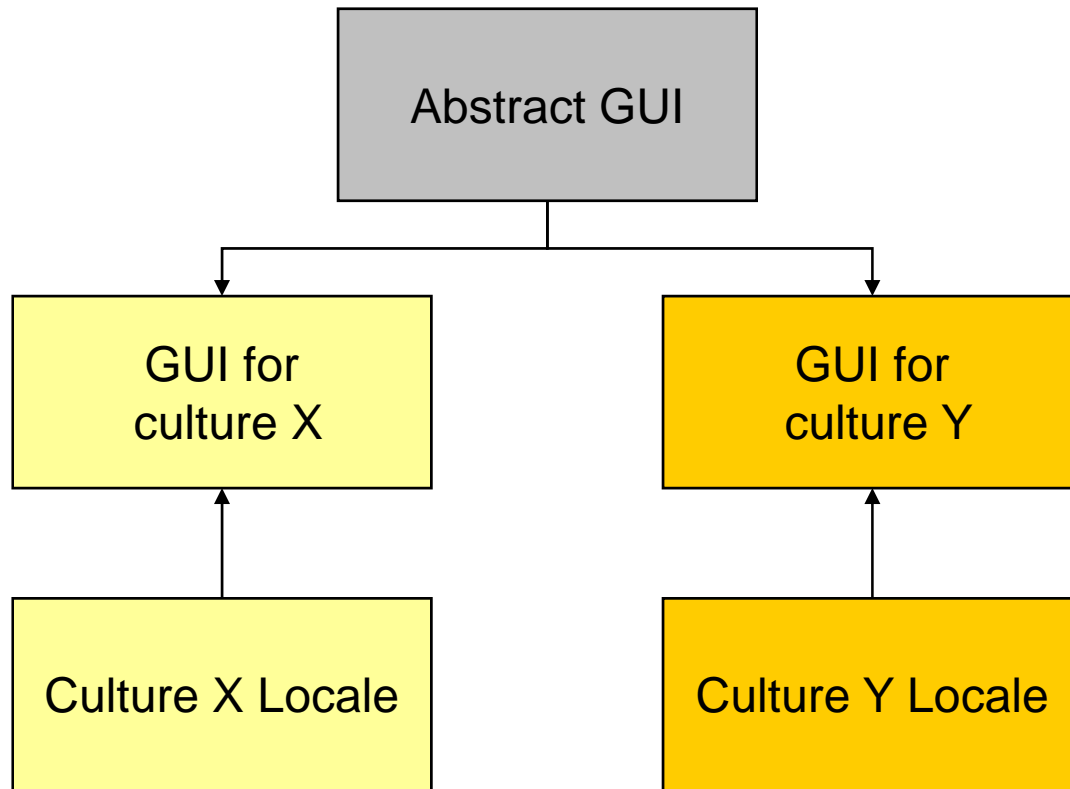

[Adapted from Kersten, 2002]



1934 2009

UNIVERSITY OF JYVÄSKYLÄ

Types of internationalization

Production

Product

Deployment

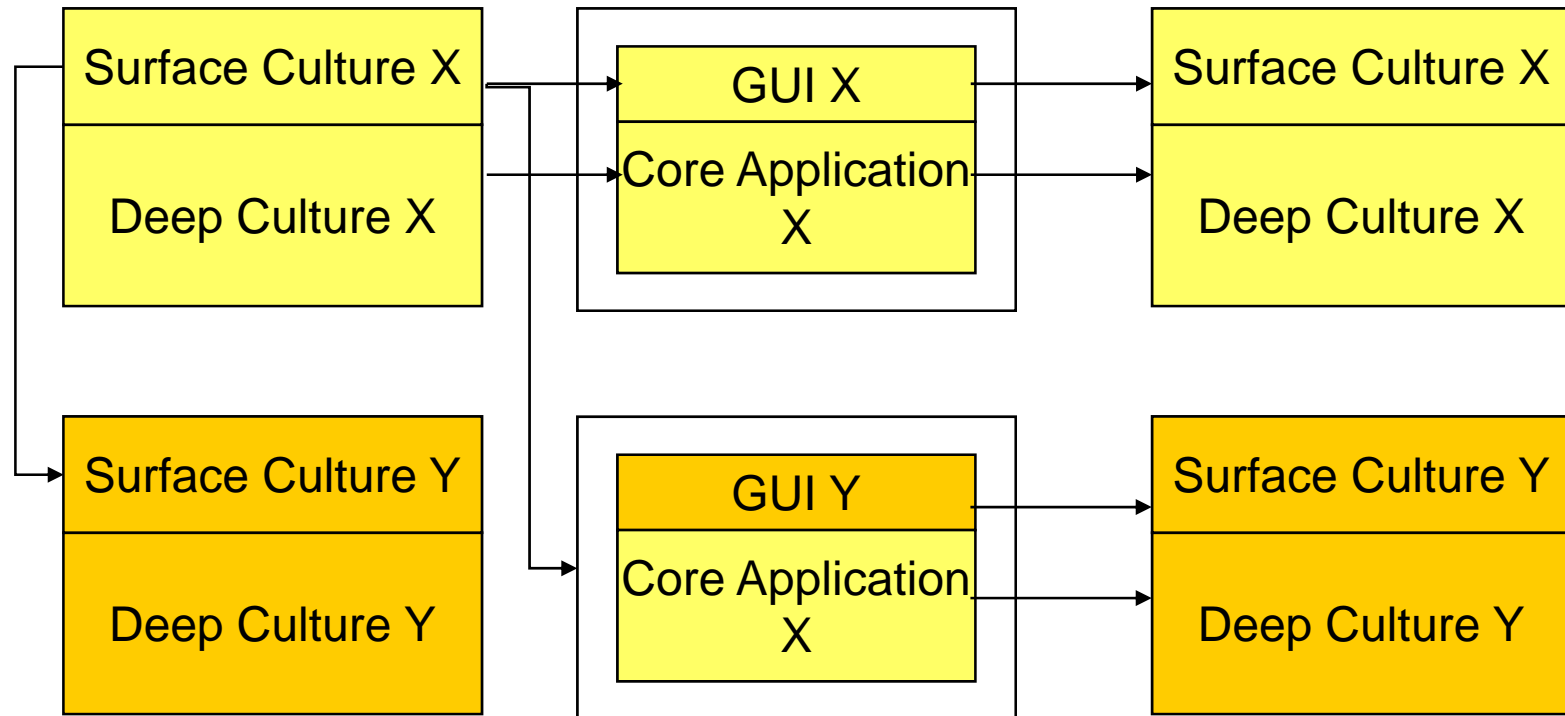

1934 2009

UNIVERSITY OF JYVÄSKYLÄ

Challenges in Localization

- Text string expansion
- Character sets and encoding
- Bidirectional text and vertical display
- Keyboard character layout, shortcuts
- Fonts
- Sorting order
- Placeholders
- Abbreviations
- Terminology
- And many more



1934 2009

UNIVERSITY OF JYVÄSKYLÄ

Aspects

- Formats
 - Date
 - Time
 - Currency
 - Addresses, Postal codes
- Symbols, icons, graphics, colors
- Language
 - Translation
 - Writing system
 - Characters
- Other
 - Contents...
 - Sounds
 - Messages
 - Measurements / Units



1934 2009

UNIVERSITY OF JYVÄSKYLÄ

Format samples

■ Dates:

- 31.10.2007, 13:15:26 CET
- 10-31-2007, 01.15.26 am CET
- 31 OCT 2007, 13 h 15 CET
- ...

■ Numbers

- 1 234 567,89
- 1.234.567,89
- 1,234,567,89

■ Additionally: Other calendars, holidays

■ Separate representation and presentation – using identifiers, string indexing

Localization by country

ISO 3166 Country Codes

Official country names used by the ISO 3166/MA	Numeric	Alpha-3	Alpha-2	Local ISO codes
 Afghanistan	004	AFG	AF	ISO 3166-2:AF
 Åland Islands	248	ALA	AX	ISO 3166-2:AX
 Albania	008	ALB	AL	ISO 3166-2:AL
 Algeria	012	DZA	DZ	ISO 3166-2:DZ
 American Samoa	016	ASM	AS	ISO 3166-2:AS
 Andorra	020	AND	AD	ISO 3166-2:AD
 Angola	024	AGO	AO	ISO 3166-2:AO
 Anguilla	660	AIA	AI	ISO 3166-2:AI
 Antarctica	010	ATA	AQ	ISO 3166-2:AQ
 Antigua and Barbuda	028	ATG	AG	ISO 3166-2:AG
 Argentina	032	ARG	AR	ISO 3166-2:AR
 Armenia	051	ARM	AM	ISO 3166-2:AM
 Aruba	533	ABW	AW	ISO 3166-2:AW

[Source: http://en.wikipedia.org/wiki/ISO_3166-1]



1934 2009

UNIVERSITY OF JYVÄSKYLÄ

Localization by language

ISO 639 Language Codes

arn		Mapudungun; Mapuche	mapudungun; mapuche; mapuce
arp		Arapaho	arapaho
art		Artificial (Other)	artificielles, autres langues
arw		Arawak	arawak
asm	as	Assamese	assamais
ast		Asturian; Bable	asturien; bable
ath		Athapaskan languages	athapascanes, langues
aus		Australian languages	australiennes, langues
ava	av	Avaric	avar
ave	ae	Avestan	avestique
awa		Awadhi	awadhi
aym	ay	Aymara	aymara
aze	az	Azerbaijani	azéri
bad		Banda languages	banda, langues
bai		Bamileke languages	bamilékés, langues

Source: http://www.loc.gov/standards/iso639-2/php/code_list.php



1934 2009

UNIVERSITY OF JYVÄSKYLÄ

But....the example of Khmer...

- Written from left to right, characters being placed also above and below the main line of writing
- Words are not separated by spaces. A space in Khmer is a punctuation sign similar to a comma

ជំរិតគឺជាផ្នែកមួយនៃព្រះនិទានរបស់ខ្មែរយើង

- A word is composed of clusters, syllemes. They are not a proper syllable, as syllables are a unit of consonants and vowels pronounced in one stroke of breath. Consonant ធ្វើ pronounced after a vowel are part of the syllable, but not part of the cluster or sylleme.

- Source: <http://sourceforge.net/projects/khmer/>



1934 2009

UNIVERSITY OF JYVÄSKYLÄ

Formats

- **Unicode** is a universal character set, ie. a standard that defines, in one place, all the characters needed for writing the majority of living languages in use on computers. It aims to be, and to a large extent already is, a superset of all other character sets that have been encoded.
- A **coded character set** is a set of characters for which a unique number has been assigned to each character. Units of a coded character set are known as **code points**. For example, the code point for the letter à in the Unicode coded character set is 225 in decimal, or E1 in hexadecimal notation. (Note that hexadecimal notation is commonly used for identifying such characters, and will be used here.)
- The **character encoding** reflects the way these abstract characters are mapped to bytes for manipulation in a computer. (W3C, 2007)



1934 2009

UNIVERSITY OF JYVÄSKYLÄ

Formats

- ❏ **Character:** The smallest component of written language that has semantic value; refers to the abstract meaning and/or shape (Unicode Glossary, 2007)
- ❏ **Visual rendering** introduces the notion of a glyph. Glyphs are defined by ISO/IEC 9541-1 [ISO/IEC 9541-1] as "a recognizable abstract graphic symbol which is independent of a specific design". There is not a one-to-one correspondence between characters and glyphs. (W3C, 2005)



1934 2009

UNIVERSITY OF JYVÄSKYLÄ

Formats: Recommendations (W3C, 2005)

- ❏ Specifications, software and content **MUST NOT** require or depend on a one-to-one correspondence between characters and the sounds of a language
- ❏ Specifications, software and content **MUST NOT** require or depend on a one-to-one mapping between characters and units of displayed text
- ❏ Protocols, data formats and APIs **MUST** store, interchange or process text data in logical order
- ❏ Independent of whether some implementation uses logical selection or visual selection, characters selected **MUST** be kept in logical order in storage
- ❏ Specifications of protocols and APIs that involve selection of ranges **SHOULD** provide for discontinuous logical selections, at least to the extent necessary to support implementation of visual selection on screen on top of those protocols and APIs



1934 2009

UNIVERSITY OF JYVÄSKYLÄ

Formats: Recommendations (W3C, 2005)

- ❏ Specifications and software **MUST NOT** require nor depend on a single keystroke resulting in a single character, nor that a single character be input with a single keystroke (even with modifiers), nor that keyboards are the same all over the world
- ❏ Software that sorts or searches text for users **SHOULD** do so on the basis of appropriate collation units and ordering rules for the relevant language and/or application
- ❏ Specifications, software and content **MUST NOT** require or depend on a one-to-one relationship between characters and units of physical storage
- ❏ More on characters and encoding:
<http://www.w3.org/TR/charmod>
- ❏



1934 2009

UNIVERSITY OF JYVÄSKYLÄ

Formats

❏ Different encodings for character sets

– ISO 8859-1

– Unicode

	A	κ	好	𠄎
Code point	U+0041	U+05D0	U+597D	U+233B4
UTF-8	41	D7 90	E5 A5 BD	F0 A3 8E B4
UTF-16	00 41	05 D0	59 7D	D8 4C DF B4
UTF-32	00 00 00 41	00 00 05 D0	00 00 59 7D	00 02 33 B4



1934 2009

UNIVERSITY OF JYVÄSKYLÄ

Recommendation samples

- ❖ Internationalisation Tag Set (W3C)
 - Used to develop localizable schemata
 - Identifying translation needs
 - Elements: Translate, localization note, terminology, directionality, language information, elements within text



1934 2009

UNIVERSITY OF JYVÄSKYLÄ

Recommendation samples

Internationalisation Tag Set (W3C)

```
<Res
  xmlns:its="http://www.w3.org/2005/11/its"
  its:version="1.0">
  <prolog
    its:translate="no">
    <revision>Sep-07-2006</revision>
    <its:rules version="1.0">
      <its:translateRule selector="//msg/notes" translate="no"/>
      <its:locNoteRule locNoteType="description" selector="//msg/data">
        <its:locNote>The variable {0} is the name of the host.</its:locNote>
      </its:locNoteRule>
    </its:rules>
  </prolog>
  <body>
    <msg id="HostNotFound">
      <data>Host {0} cannot be found.</data>
    </msg>
    <msg id="HostDisconnected">
      <data>The connection with {0} has been lost.</data>
    </msg>
    <msg id="FileNotFound">
      <data
        its:locNote="{0} is a filename">{0} not found.</data>
      </msg>
  </body>
</Res>
```

[Source: <http://www.w3.org/TR/2007/REC-its-20070403>]



1934 2009

UNIVERSITY OF JYVÄSKYLÄ

“Culturalization” of applications

- Culture awareness
 - Adapting business logic
 - Adapting contents
 - Adapting user interfaces
-
- Samples for culturally adapted interfaces



1934 2009

UNIVERSITY OF JYVÄSKYLÄ

Types of internationalization

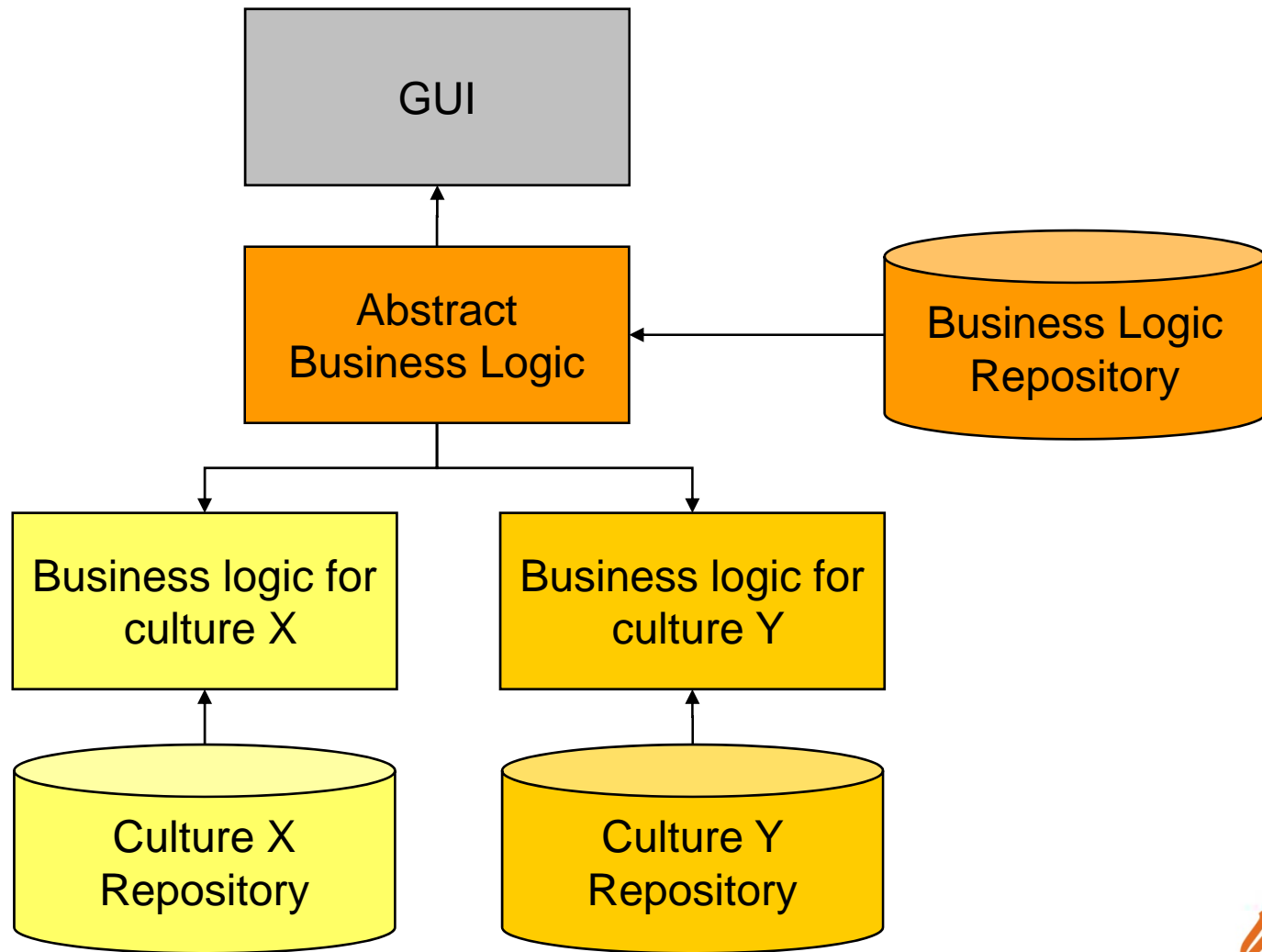

[Adapted from Kersten, 2002]



1934 2009

UNIVERSITY OF JYVÄSKYLÄ

Culture-aware internationalization

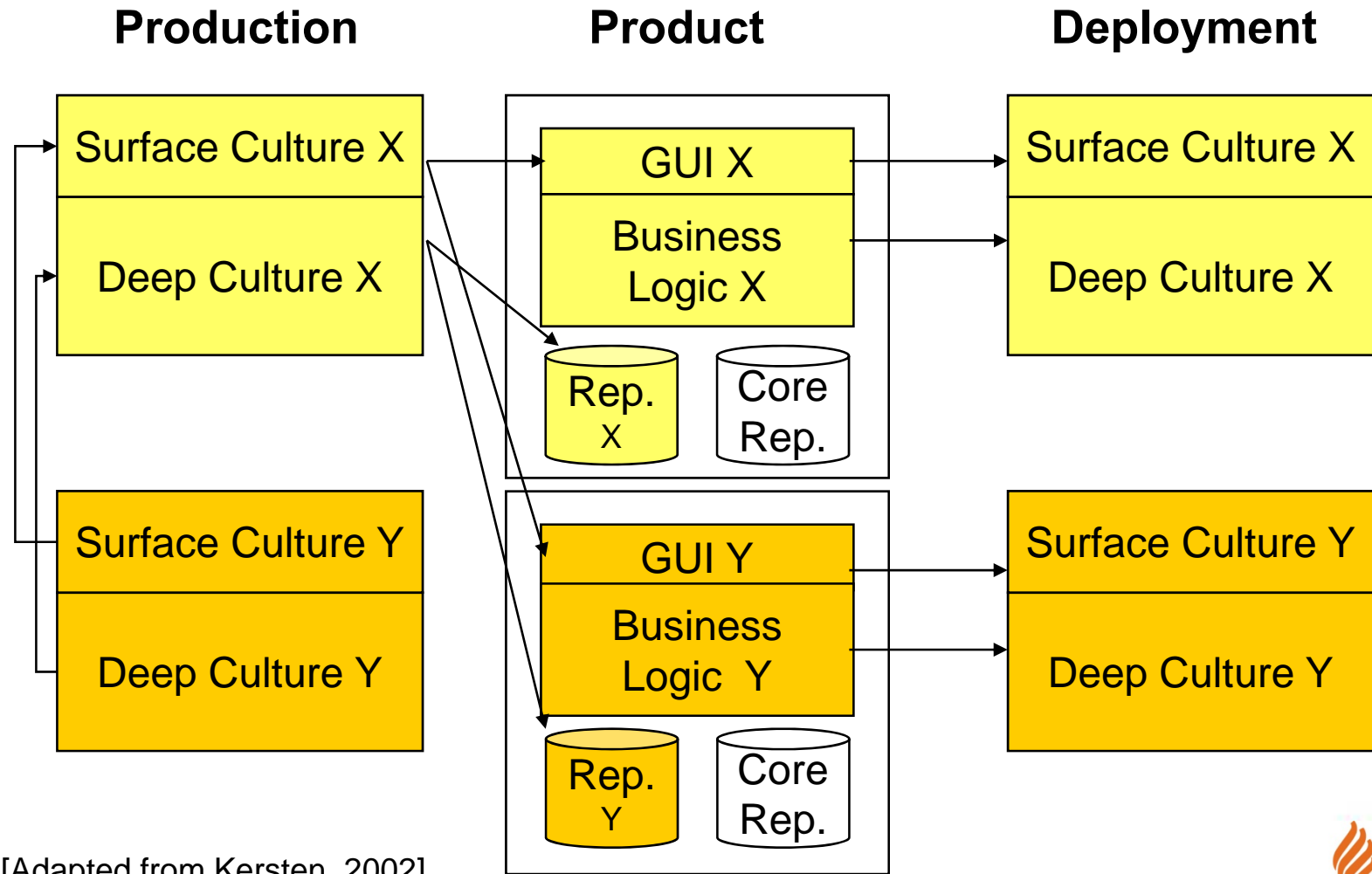

[Adapted from Kersten, 2002]



1934 2009

UNIVERSITY OF JYVÄSKYLÄ

Interface Design Strategy (Jagne et al., 2004)

- ❏ Investigation
 - Ethnographic study
 - Site / software audits
 - Interviews & observations
- ❏ Develop cultural model
 - Similarities, differences
- ❏ Design prototype interface
 - Localization
- ❏ Evaluate prototype
 - Acceptance, conflicts, user behavior
 - Contents, media appropriateness
 - Tracking, observations, interviews



1934 2009

UNIVERSITY OF JYVÄSKYLÄ

User Interface Design

- **Aspects to consider (Marcus, 2001)**
- **Metaphors:** Fundamental concepts communicated via words, images, sounds, and tactile experiences. Concepts of pages, shopping carts, chatrooms, and blogs (Weblogs) are examples. The pace of metaphor invention and neologism will increase because of rapid development, deployment, and distribution through the Web.
- **Mental models:** Structures or organizations of data, functions, tasks, roles, and people in groups at work or play. Content, function, media, tool, role, and task hierarchies are examples.
- **Navigation:** Movement through the mental models, i.e., through content and tools. Examples include dialogue techniques such as menus, dialogue boxes, control panels, icons, tool palettes, and windows.
- **Interaction:** Input/output techniques, including feedback. Examples include the choices of keyboards, mice, pens, or microphones for input and the use of drag-and-drop selection/action sequences.
- **Appearance:** Visual, auditory, and tactile characteristics. Examples include choices of colors, fonts, verbal style (e.g., verbose/terse or informal/formal), sound cues, and vibration modes.



User Interface Design – Issues

- **Some questions to think about (Marcus, 2000)**
- How formal or rewarding should interaction be?
- What will motivate different groups of people? Money? Fame? Honor? Achievement?
- How much conflict can people tolerate in content or style of argumentation?
- Should sincerity, harmony, or honesty be used to make appeals?
- What role exists for personal opinion vs. group opinion?
- How well are ambiguity and uncertainty avoidance received?
- Will shame or guilt constrain negative behavior?
- What role should community values play in individualist vs collectivist cultures?



1934 2009

UNIVERSITY OF JYVÄSKYLÄ

User Interface Design – Issues (2)

- **Some more questions to think about (Marcus, 2000)**
- Does the objective of distance learning change what can be learned in individualist vs. collectivist cultures?
- Should these sites focus on tradition? Skills? Expertise? Earning power?
- How should online teachers or trainers act – as friends or gurus?
- Would job sites differ for individualist vs. collectivist cultures?
- Should there be different sites for men and women in different cultures?
- Would personal Webcams be OK or Not OK?
- How much advertising hyperbole could be tolerated in a collective culture focused on modesty?
- Would an emphasis on truth as opposed to practice and virtue require different types of procedural Websites for Western or Asian audiences?



1934 2009

UNIVERSITY OF JYVÄSKYLÄ

At the end of this phase, the following results should be ready:

- ❏ Strategy for internationalization & localization
 - Design planning
 - Architecture refinement
 - Standards, guidelines
- ❏ User interface design
 - Cultural profiles for user groups
 - Design guidelines
 - Design prototypes



1934 2009

UNIVERSITY OF JYVÄSKYLÄ

Summary

- ❏ There is no one-fits-all strategy for internationalization and localization
- ❏ Standards should be considered
- ❏ Based on a culture analysis, (internal) guidelines should be developed
- ❏ Prototyping and participating is essential
- ❏ Other individualization / personalization strategies should be considered



1934 2009

UNIVERSITY OF JYVÄSKYLÄ

Questions

- ❏ Describe the differences of globalization, internationalization, localization and adaptation.
- ❏ Which aspects should be considered when designing and developing international solutions
- ❏ Which guidelines can be applied for designing a website for a Finnish university?
- ❏ Which steps are necessary to develop an Asian marketing site for JYU?

References

- Hogan, J.M., Ho-Stuart, C., Pham, B. (2003): Current Issues in Software Internationalisation. Australian Computer Science Conference, Adelaide, May2003.
- Kersten, G.E., Kersten, M., Rokaowski, W.M. (2002): Software and Culture: Beyond the Internationalization of the Interface, Journal of Global Information Management, 10(4), 2002.
- Marcus, A. (2000): Cultural Dimensions and Global Web User-Interface Design: What? So What? Now What? IN: Proceedings of the 6th Conference on Human Factors and the Web in Austin, Texas, 19 June 2000

Contact Information ITRI

▣ **Prof. Dr. Jan M. Pawlowski**

▣ **jan.pawlowski@titu.jyu.fi**

▣ **Skype: jan_m_pawlowski**

▣ **Office:**

▣ **Telephone +358 14 260 2596**

▣ **Fax +358 14 260 2544**

▣ **<http://users.jyu.fi/~japawlow>**



1934 2009

UNIVERSITY OF JYVÄSKYLÄ